

GLASTAR SERVICE BULLETIN 23

Subject: Door latch modification

Applicability: All GlaStar kits shipped prior to the publication of *Assembly Manual* Revision C.

Discussion: We have had reports from some early builders of finished GlaStar aircraft that the doors do not remain firmly latched in flight. In some cases, the over-center springs are not strong enough to prevent the door latches from moving up the sloped legs of the door latch dogs, allowing the door to pop open.

Recommended Action: There are several possible solutions to this problem, not all of which may be necessary. The solutions consist of reshaping the door latch dogs to reduce the tendency of the door latches to work free, installing a second over-center spring on each side and adding extensions to the door latch arms.

RESHAPE THE DOOR LATCH DOGS: When bending the door latch dogs, bend them to the shape shown in Figure 1 of this service bulletin, rather than the shape described in Step 114 of "SECTION X: FINAL ASSEMBLY" in the *Assembly Manual*. Obviously, the latch will have much less tendency to "climb" out of the latched position with the dog shape shown here. If you have already bonded the latch dogs to the door frame, you will have to remove the original dogs and start over, although you might want to try the additional over-center springs first, as described below; the additional springs could adequately retain the latches even with the original dogs.

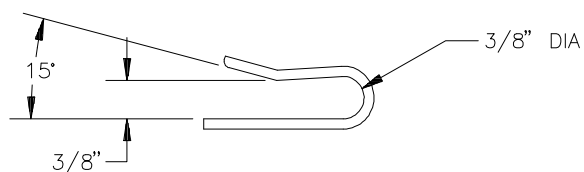
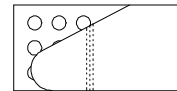

Figure 1: Latch Dog Specifications

INSTALL A SECOND OVER-CENTER SPRING: The standard door latch configuration has been revised to include **two** over-center springs on each side. Installing the second spring is optional for builders of earlier kits who have already installed their latches; such builders may want to wait to decide whether to upgrade until they have flown their airplanes—it may turn out that just the new dog shape (if the original dogs weren't installed) eliminates any tendency for the doors to open in flight.

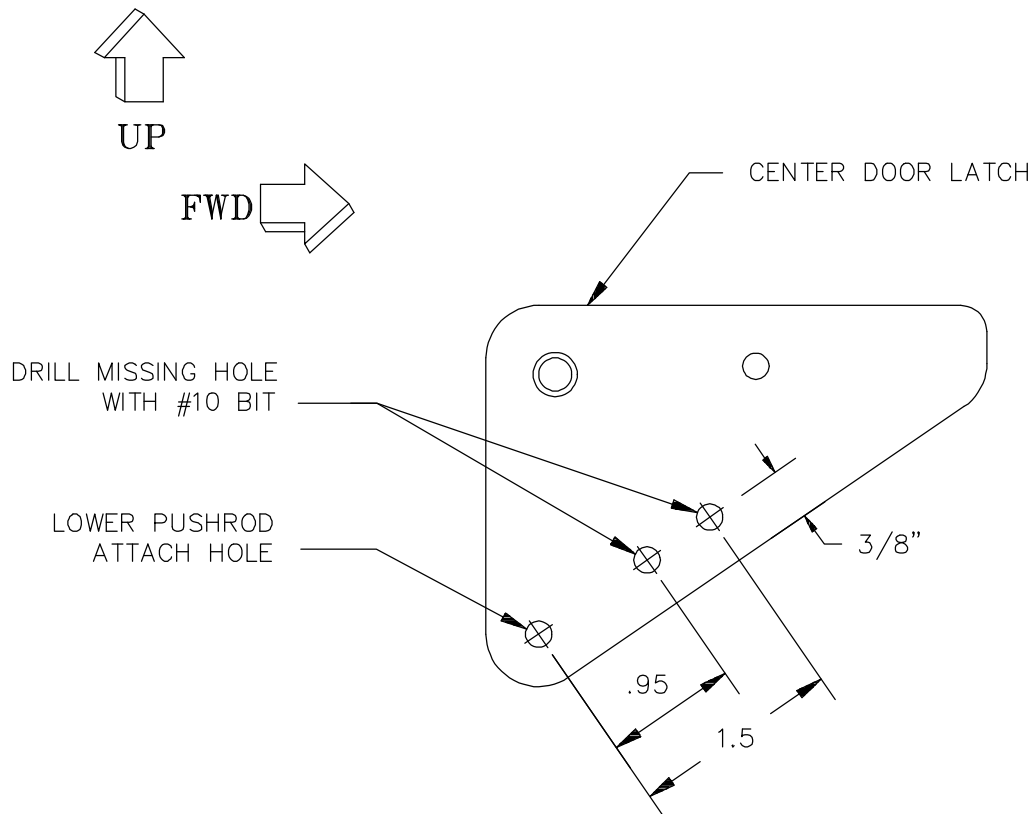

Figure 2: Modifying the Center Latch Plate

In order to facilitate installing the second over-center spring at a later date, if needed, we recommend drilling an additional hole in each of the center latch plates to bring the latches up to current specifications. Figure 2 shows the current latch, which has **two** #10-diameter holes along its lower edge spaced **.95"** and **1.5"** from the lower pushrod-attach hole. Early latches had one or the other of these holes, but not both. If your latch has a hole .95" from the pushrod-attach hole, drill a **#10-diameter hole 1.5"** from the pushrod-attach hole; if your latch has the hole at 1.5", drill a **#10-diameter hole .95"** from the pushrod-attach hole. Repeat for both center latches.

If you elect to use just the one spring originally specified, attach its lower end to the hole that is **1.5"** from the pushrod-attach hole in the center latch plate, using the hardware shown in Figure 130 in SECTION X of the *Assembly Manual*. Attach the upper end of the spring to the upper shell attach fitting, as described in the *Assembly Manual*. If you use two springs, install them as shown in Figure 3, below. Both springs in Figure 3 use the same attach hardware at their lower ends as that shown for the single spring in Figure 130.

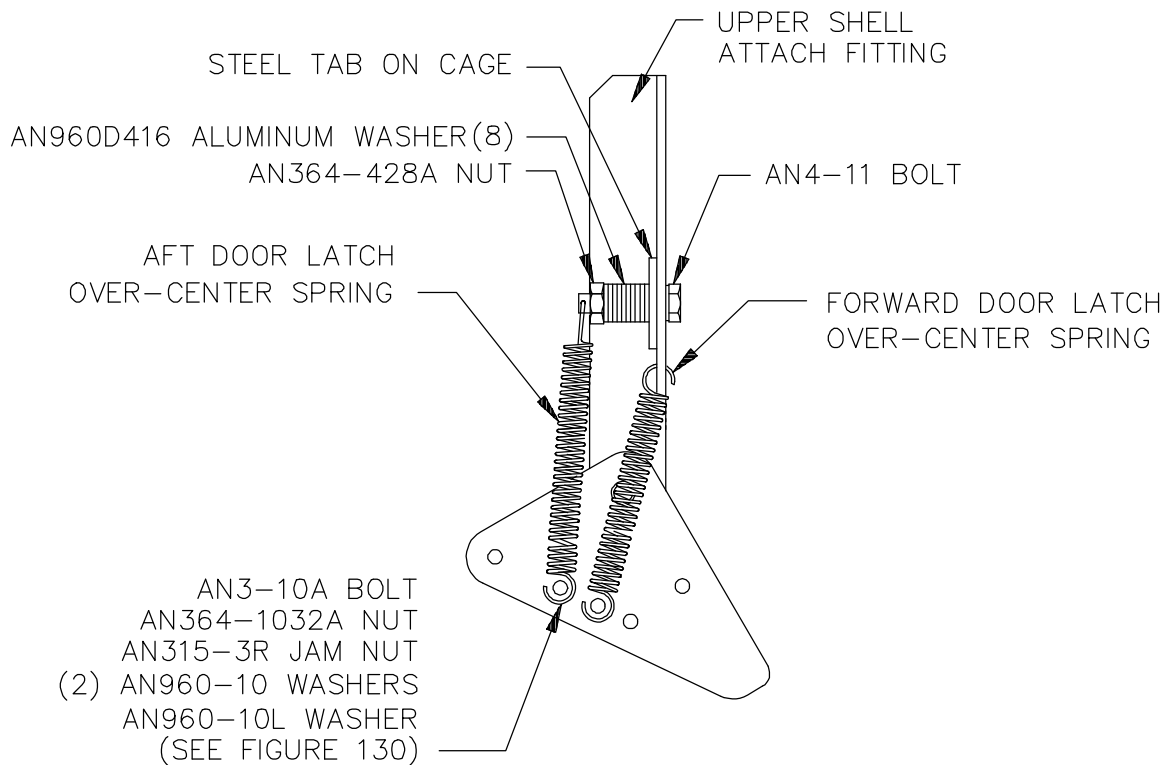

Figure 3: Dual Over-Center Spring Installation



Note The second over-center spring and its mounting hardware were not included in early kits, but they will be supplied in a Parts List Addendum. You will receive two each of the **forward door latch over-center springs** (P/N 077-00002-02), two each **AN4-11** bolts, two each **AN3-10A** bolts and two each **AN315-3R** jam nuts. Various washers and elastic stop nuts are also needed in the installation, but there should be enough extra of these in the original kit to satisfy your needs. Use the original spring supplied with your kit as the **aft** spring.

EXTEND THE DOOR LATCH ARMS: It's possible that some of the door latch arms (the forward upper latch arms, in particular) may inadequately engage the door dogs. If the ends of the forward upper door latch arms are not visible beyond the door latch dogs when the latches are closed, double flush rivet **1/16"-thick aluminum extensions** onto the arms, as shown in Figure 4. The extensions will help retain the latch arms more securely in the dogs. Alternatively, you can purchase the redesigned forward upper door latches (P/N 101-16001-03 and -04), which are 1/2" longer. If any of the **builder-fabricated** door latches are too short, make new, longer ones.

To double flush-rivet the extensions on the forward upper latches, simply countersink **both** parts and then buck the rivets normally, allowing the shop head to deform into the countersink on the back side. Any part of the shop head that protrudes beyond the surface after bucking can be filed off flush. The shop head won't completely fill the countersink, but it will spread out enough to securely retain the extension.

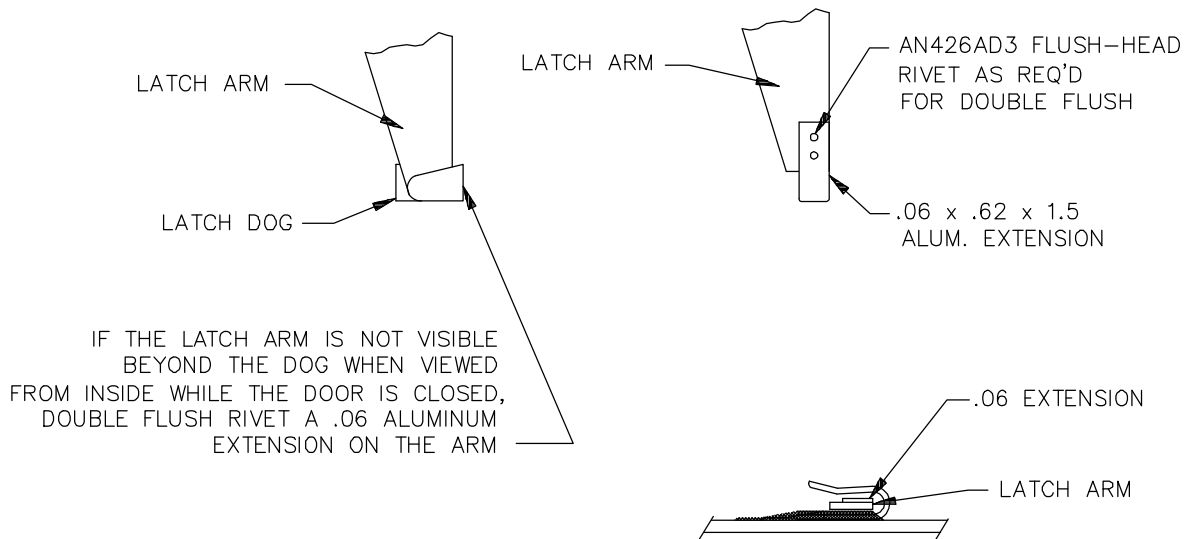

Figure 4: Latch Arm Extensions